

29:128

Homework 0

reference: Chapter 1 of Horowitz and Hill

- (1) In the circuit shown below, $V_{in} = 9\text{ V}$, $R_1 = 1.5\text{ k}\Omega$, $R_2 = 5.6\text{ k}\Omega$,
- Calculate V_{out}
 - Calculate the power dissipated in R_1 and R_2 .
 - Is a $\frac{1}{4}$ Watt resistor sufficient, or should you buy a resistor rated for a higher level of heat dissipation?

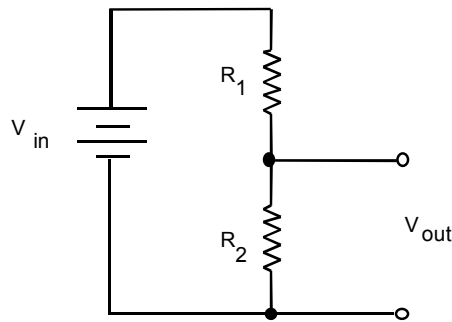

- (2) Repeat (1), but with $R_1 = 1.5\ \Omega$, $R_2 = 5.6\ \Omega$.
- (3) Suppose you have two ac signals, which we'll call signals A and B , which have peak-to-peak amplitudes of 30 mV and 600 mV, respectively.
- What is the dB for signal A , as compared to signal B ?
 - Your answer to (a) was either positive or negative. What is the significance of this sign?
 - What are the rms voltages for signals A and B ?

29:128

Homework 1

reference: Chapter 1 of Horowitz and Hill

note: this homework assignment requires the use of MultiSym to simulate a circuit.

(1) Easy voltage divider problem.

- (a) Use Multi-sym to make a voltage divider circuit as shown, as shown in the screen shot to the right. For the resistors, use a “virtual” resistor, and add a multimeter as shown. Attach printouts of (i) the circuit and (ii) the multimeter display (it’s called an “instrument map” in Multisym’s print menu).

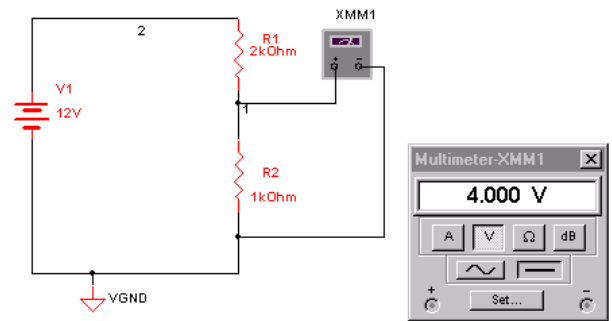

- (b) Now change the component values to the following: $V1 = 9\text{ V}$, $R1 = 1.4\text{ k}\Omega$ and choose a value for $R2$ that will result in an output voltage of 5.0 V. Attach printouts of the circuit and multimeter display.

(2) *(This problem is related to a diode experiment in Laboratory 3, and you will find the problem easiest to do, after you have done the lab).*

See Horowitz & Hill Exercise 1.27

- (a) Solve the problem on paper. What you are supposed to do is choose the values of (i) the rms output of the transformer and (ii) the value of the capacitor. (Be careful not to confuse rms with peak values. Note that the frequency of electrical power in North America is 60 Hz. Pay attention to diode drops.)
- (b) What type of capacitor (ceramic, mylar, etc.) would you use?
- (c) What is the value of the load resistance R_{load} , if the output current is $I_{\text{out}} \leq 10\text{ mA}$. (Specify your result as either $R_{\text{load}} \leq X\ \Omega$ or $R_{\text{load}} \geq X\ \Omega$, whichever is appropriate.)
- (d) Set this circuit up as a simulation, using Multisym, using the values you found in part (a). Instead of using Multisym’s transformer, use its ac voltage source, and specify the peak voltage corresponding to your result for 2 (a) (i).
- (i) Choose the load resistor that you calculated for $I_{\text{out}} = 10\text{ mA}$. Your circuit should begin with an ac voltage source that produces the ac voltage that you calculated in (a) as the desired output of the transformer. Be careful not to confuse rms with peak values of voltage. Attach a printout showing the circuit.



ac voltage source

(ii) Set up an “oscilloscope” display. Do this two ways, dc coupled to show the dc output level, and ac coupled to better show the ripple. (Be sure to choose vertical and horizontal scales that are suitable so that the signal with its peaks is easily seen and measured.) Use the two cursors to measure the voltage at the maximum and the minimum of the ripple. Attach printouts of the oscilloscope display (it’s called an “instrument map” in Multisym’s print menu), once for dc coupling, and once for ac coupling.¹

- (3) Suppose that you now decide that what you really want is a 5.0 V power supply. Here you will test two ways of adding components to your circuit to achieve a 5.0 V output.
- (a) (i) First, eliminate the load resistor, then after the filter capacitor, add a zener regulator, consisting of 5 V zener diode (for example, Philips BZV85-C5V1) with a series resistor. (ii) Choose a reasonable value for the series resistor.² After the zener regulator, add a load resistor across the output, choosing a value to achieve a load current of 10 mA (at 5 Volts). Attach a printout of your circuit.
- (iii) Set up an “oscilloscope” display first with dc coupling showing the peak dc output and then with ac coupling showing the peak-to-peak ripple. (Be sure to choose vertical and horizontal scales that are suitable so that the signal with its peaks is easily seen and measured.) Using the cursor measurements, calculate the peak-to-peak ripple, or write down a sentence stating that that it is zero if the ripple is too small to measure. Attach printouts of the oscilloscope display.
- (iv) Repeat (iii) with the load resistance increased to 1 G Ω (so that there is essentially zero output current through the load).
- (b) Repeat parts ii-iv above, but instead of the zener diode and its series resistor, use a pair of resistors in series, to form a voltage divider to achieve the desired output voltage of 5 V. Choose the resistors yourself, to achieve the desired voltage when the load resistor is the value you found in question 1 (a).

¹ For ac coupling, allow the oscilloscope trace to refresh itself once or twice before stopping and printing, otherwise you will only see an uninteresting transient at the beginning.

² Assume that a reasonable value for the series resistor is in the range 100 – 1000 Ω . Try out 100 Ω and then 1000 Ω , to see which gives you a smaller ripple and then use that value for the results that you report.

(c) Fill out this table, and attach it to your solutions that you hand in:

<i>Method of reducing output voltage to 5 V.</i>	<i>dc output voltage (V)</i>	<i>ripple voltage peak-to-peak (mV)</i>
Zener regulator, with 10 mA output current through load		
Zener regulator, with 0 mA output current through load		
Difference in DC voltage		XXXXXXXXXX XXXXXXXXXX

Voltage divider, with 10 mA output current		
Voltage divider, with 0 mA output current through load		
Difference in DC voltage		XXXXXXXXXX XXXXXXXXXX

(d) Which method of reducing the output voltage to 5 V is more desirable (voltage divider or zener)? Write down *two* reasons for your answer.

29:128

Homework 2

reference: Chapter 2 of Horowitz and Hill

note: this homework assignment requires the use of MultiSym to simulate a circuit.

- (1) Common emitter amplifier. Use Multisim to connect the circuit shown in the screen shot below.
 - (a) The value of R2 is not shown. (i) Choose a standard value for 5% resistors, as tabulated in Appendix C, to achieve a base bias that results in the most symmetric output waveform possible. Show your calculation, including a result for the base bias that you intend to achieve. (ii) Run the simulation with a sine wave amplitude of approximately 600 mV and observe the clipping. (iii) Vary the value of R2 to test whether you chose the optimal value. After you are certain that you have chosen the optimum value of a standard 5% resistor,

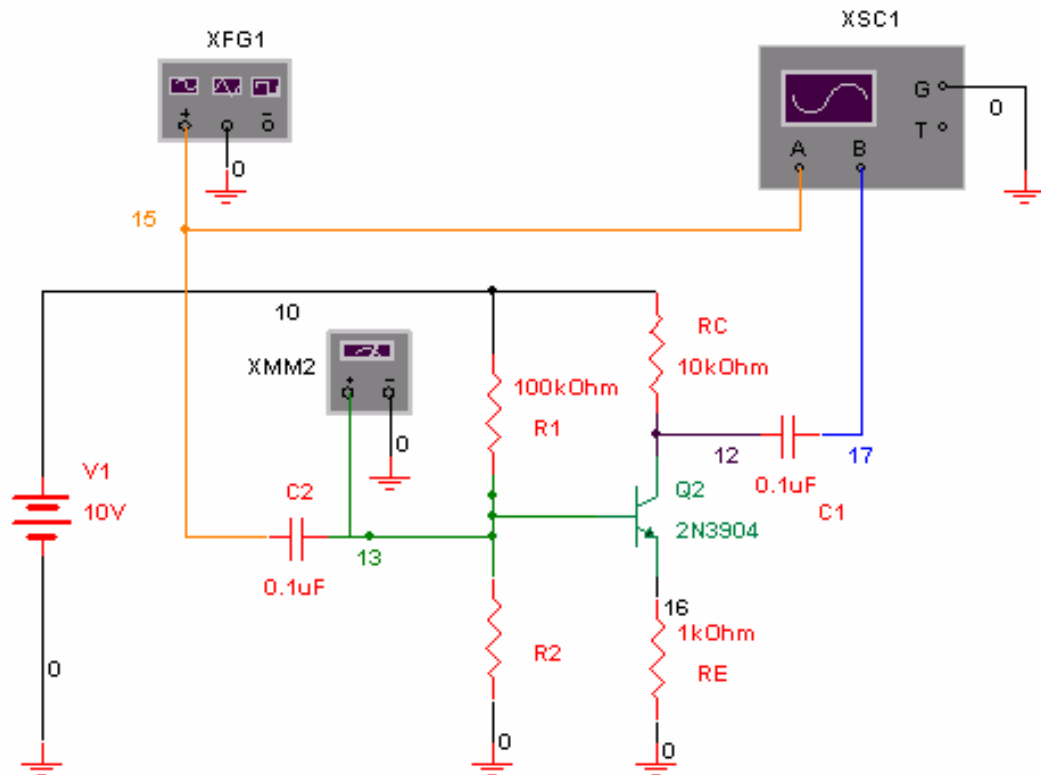

attach a printout³ of the circuit schematic diagram as shown below (but showing the value of R_2), and a printout of the oscilloscope display showing the clipping of the output waveform. (iv) Use the multimeter to measure the dc voltage on the base, and report this value.

- (b) Reduce the input voltage amplitude to ~ 100 mV. Use the cursors to measure the input and output waveforms, at the maximum and minimum values. Calculate the ratio, including a minus sign if any, and report this as the gain. Repeat for $R_C = 2$ k and $R_C = 5$ k. Compare to the theoretical values. Report your results in a table:

	Measured gain	Theoretical gain
$R_C = 2$ k		
$R_C = 5$ k		
$R_C = 10$ k		

- (2) Transistor switch. (Note: it is not necessary to attach any printouts for this problem.)

Solve the following problem on paper. You wish to make a transistor switch to turn a 1-Watt 20-Volt light bulb on and off. You wish to use a 2N4401 transistor to do this. You want to choose the base resistor R_b so that the transistor operates in the saturated mode when the base is connected to the positive side of the power supply. This is what you are to design. See Appendix K of Horowitz and Hill for the data sheet for this transistor.

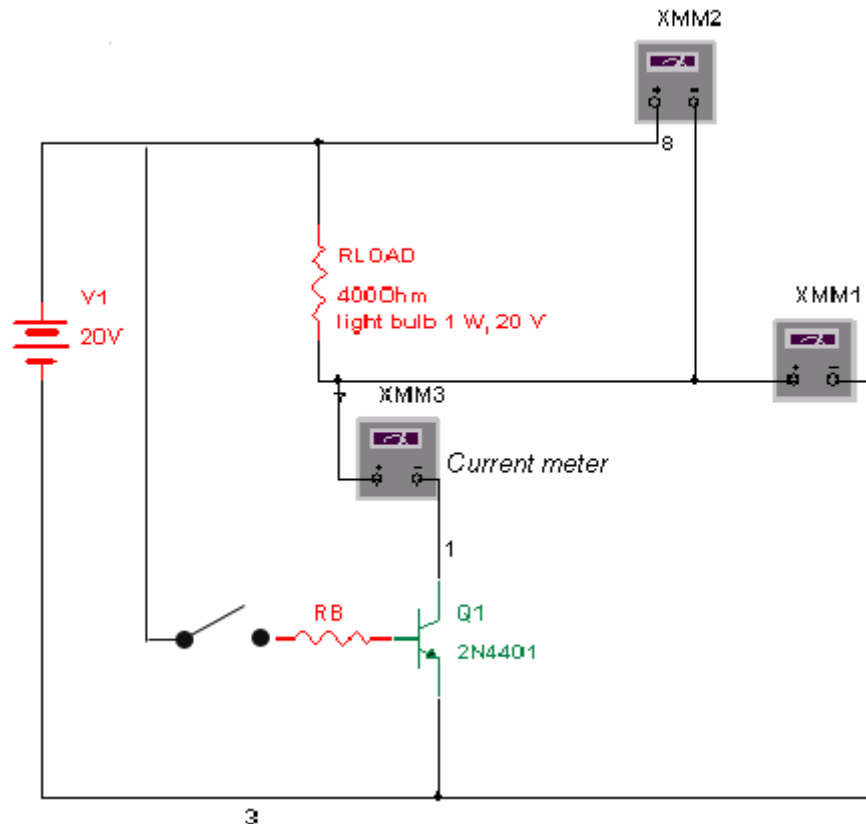

- Find the ratio I_c / I_b for which saturation conditions are specified in the transistor spec sheet. (Look in the figures.)
- Calculate the collector current I_c passing through the lightbulb, if it is to operate at its nominal parameters of 1 W at 20 V. Calculate the corresponding base current I_b , using the ratio that you found in the previous step.
- Find the value of the base-emitter diode drop, at saturation conditions, from one of the figures in the data sheet.
- Calculate the voltage drop across the base resistor, when it is connected to the positive side of the power supply.
- Calculate the corresponding value for the base resistor. We'll call this value R_{temp} .

- (f) The resistor value R_{temp} that you calculated is probably not a standard value. First decide whether to make the value larger or smaller than R_{temp} , based on the criterion that you would rather be farther into saturation, and not closer to normal mode operation, as a result of your adjustment. You will want to use a 5% tolerance resistor, so adjust R_{temp} either up or down by 5%, according to the direction you decided above. Then choose the nearest standard value for 5% transistors, again adjusting in the direction you decided above. Report your result.
- (g) Set this circuit up as a simulation, using Multisym, using the base resistor value that you found above. Add a wire connecting the base resistor to the positive power supply voltage. Measure the voltage across the load resistor and across the transistor, and measure the current flowing through these two devices. Calculate the power dissipated in both components, and fill out the table below. Please report your values in the units shown (don't use mV when it says V, for example):

Switch "ON"	Load resistor	Transistor
Voltage drop (V)		
Current (mA)		
Power dissipated (W)		

Now repeat with the base resistor disconnected, as shown in the screenshot above, to measure the conditions for "OFF."

Switch "OFF"	Load resistor	Transistor
Voltage drop (V)		
Current (mA)		
Power dissipated (W)		

Discuss in words the following two issues:

- (i) how do the tables above show that the switch turns the power in the load on and off, as desired?
- (ii) is the power dissipated in the transistor sufficiently low, compared to the maximum rating for the total device dissipation rating of this transistor (as indicated in the transistor's data sheet)?

29:128

Homework 3

reference: Chapter 4 of Horowitz and Hill

note: this homework assignment requires the use of MultiSym to simulate a circuit.

(1) Exercise 4.2 in text.

- Show that $I_{load} = -V_{in} / R_2$.
- Provide a consolidated list of the principles and/or rules that you invoke in your solution
- Note:
 - Be sure to recall that an opamp output can source or sink current
 - Do this on paper ... this problem does not require MultiSym.

(2) Exercise 4.3 in text. (Note: do this on paper ... this problem does not require MultiSym.)

- (a) For circuit A, show that gain = +1 with the switch in the follower position, and that gain = -1 with the switch in inverter position.
- (b) Repeat, for circuit B.

(3) Exercise 4.5 in text. (Do this on paper ... this problem does not require MultiSym.)

(4) Active Peak Detector.

- (a) Using Multisym, connect the circuit shown below. The two function generators should produce sine waves at 10 Hz and 160 Hz, each with an amplitude of 0.5 Volt. Use a “virtual” capacitor. Verify that the active peak detector works as shown in Figure 4.39 of the textbook. Attach printouts of your circuit diagram and the oscilloscope display (be sure to choose oscilloscope settings that are reasonable, and so that your result looks something like Figure 4.39. (If necessary,

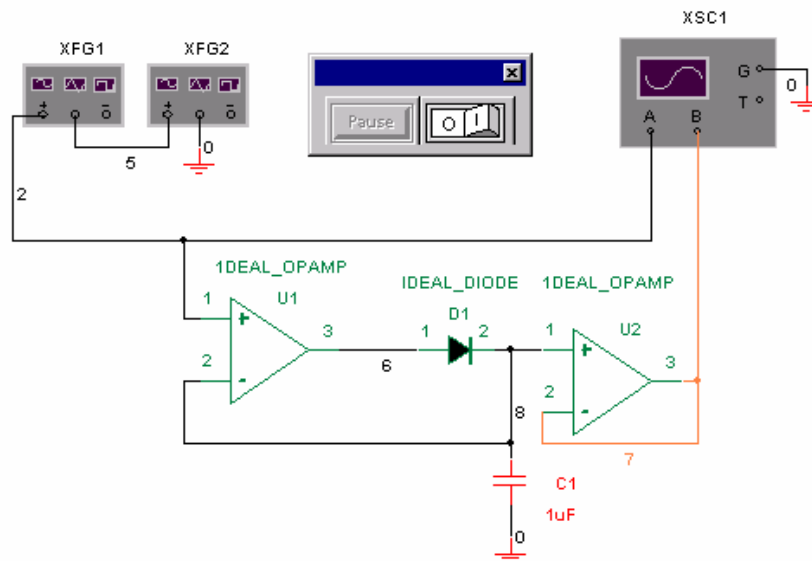

- you can set the time step for the instruments using the “Simulate / Default Instrument Settings ...” menu.)
- (b) Repeat, but without the two op-amps, so that you have a passive peak-detector as shown in Figure 4.37 of the textbook. Attach printouts of your circuit diagram and the oscilloscope display. Explain why your results appear to be different from the active peak detector in part (a). This circuit has other disadvantages as well; identify one that cannot be simulated easily using Multisym.

29:128 Homework 4

- (1) Exercise 5.8 in text. Show that the period of this 555 timer circuit is
- $$T = 0.693 (R_A + 2 R_B) C.$$

Hint – review pp. 23-24 in text for capacitor charging.

29:128 Homework 5

Digital Electronics:

Do Exercises 8.7, 8.9, 8.12 in text (Horowitz and Hill).